

# AG PUMP



## INSTRUCTION MANUAL



 **Plastica**

The UK's Leading Independent Swimming Pool Manufacturer and Distributor

 [www.plasticapools.net](http://www.plasticapools.net) Find us on      

Address: Perimeter House, Napier Road, St Leonards on Sea, East Sussex, TN38 9NY  
Plastica Limited is registered in England and Wales with Company Number 1856576 and VAT Number: 100 1630 93

## INSTALLATION

- The pumps are recommended for use in swimming pools and garden pools but are highly adaptable to salt water applications. Maximum pressure, head max, is given on the pump registration plate.
- Ensure your pump is in an accessible location for servicing.
- The pump should be bolted to a solid floor e.g concrete, to minimise vibration and movement.
- It is preferable for the suction inlet on the pump to be as close to the pool water level as possible.
- Please make sure there is adequate drainage should flooding occur.
- Ensure the room temperature is lower than the specified maximum ambient temperature. There must also not be extreme levels of moisture in the room. The ambient temperature must not exceed 40°C
- Please allow for isolation valves in suction and return piping, also please use a short direct suction pipe to reduce friction losses.



## PIPE

- Please make sure that all the pipe is adequately supported around the pump. Avoid any straining on the pipework and joints.
- Please ensure that the suction pipe is the same or larger than the return inlet.
- To prevent air locking, slope the inlet pipe at a slight angle up towards the pump. Try to avoid using fittings that cause air locking/air traps. All pipe must be air tight.
- For flooded suction systems, please ensure you have suitable valves in suction and return pipes.
- Please ensure that all the pipe on install is new or at least cleaned before use with the new unit.
- On new installs try to use the lowest number of fittings, this will increase flow rate and increase the efficiency of the pump.
- When tightening the unions excessive torque is unnecessary and may cause damage to the pump.
- All pool fittings must conform the IAPMO (International Association of Plumbing and Mechanical Officials).



## ELECTRICAL



- Please ensure that a licensed and qualified electrician is installing the pump to Electrical Codes and Standards.
- Carry out a full visual inspection of the product, should the supply cable be damaged it must be replaced by the manufacturer or its service agent or a similarly qualified person to avoid hazards.
- Please ensure that the supply voltage matches the motor plate on the motor, if incorrect serious damage can be inflicted and void the warranty 6% is allowed either side of the recommended voltage. If the supply is more than 10% different, make sure you do not connect the pump and contact your energy supplier.
- Use an RCD (Residual Current Device) or an GFCI (Ground Fault Circuit Interrupter) not exceeding 30\_mA with a 3mm minimum break distance on each terminal. This will be the master on/off switch and will detect any short circuit to ground. Power will be shut off before it becomes dangerous for pool users.
- Before carrying out any work on your pump please make sure you isolate the power to the motor. This is imperative and can be fatal if not followed.
- Should the GFCI/RCD trip and will not reset call a licensed and qualified electrician to attend.
- The pump needs to be on its own circuit with no other lights or appliances on the same circuit.
- After wiring the pump be sure to replace and tighten the screws on the electric housing to ensure the water tight seal.

## OPERATION

- **NEVER RUN THE PUMP DRY.** It WILL damage the seals inside the pump and may cause leaking and flooding.
- Never open the pump lid to access the strainer before shutting down the pump and shut all valves in both the suction and delivery pipes. Always release the pressure from the system before access.
- Do not tighten or loosen the lid while the pump is operation.
- **DANGER HAZARDOUS SUCTION.** Body parts, hair and clothing could be trapped in the suction causing severe injury or death. NEVER block the suction.

## PRIMING

- Release all the air from the filter and pipe (see the filter manual for instructions).
- With a flooded suction system, the pump will prime itself providing the delivery valves are open.
- Re-lubrication and cleaning of the O-Rings if the lid is removed is good practice on lid and unions, use Silicone O-Ring Grease.
- Make sure that you fill the strainer basket and pump with water via the lid before starting the pump. This is a great way of ensuring a clean start-up.
- Be sure that when you are tightening up the clear lid that you only do so by hand, the lid tool is only for the purpose to remove the lid should it become too tight.
- If the pump is having difficulty priming, make sure that all the valves are open, the suction points are fully submerged and there are no leaks in the pipe.

## STORAGE AND WINTERISING



- Your pump under no circumstances can be left to freeze. This will void the warranty Also refrain from using all anti-freeze solutions apart from Propylene Glycol products, this is non-toxic and will not harm the pump unlike others.
- Make sure that the pump is winterised correctly by draining the pump and pipework of all water. This is more important during freezing temperatures and when the pump is stored for extended periods of time.
- When storing the pump make sure its covered and in a dry ventilated location. Please avoid covering the pump with anything like plastic that can cause condensation and lead to corrosion.

## DRAINING

1. **DANGER** Before draining your pump TURN OFF the power, failure to do so can cause dangerous or fatal electric shock.
2. Remove the clear strainer basket lid, there is a tool provided should the lid be too tight to undo by hand.
3. Remove the drain plug located on the strainer basket end, rotate anti clockwise to release, remove the strainer basket and check that there is no trapped debris blocking the drain hole located below the basket.

## START-UP AFTER WINTER



1. Remove any insulation you may have put around the pump during shut down.
2. Refer to your Filter Instruction Manual for restarting after winterising.
3. Carry out a full visual inspection of the electrical wiring, should you find a fault contact your qualified electrician to repair.
4. Inspect all the pipe fitting connections.
5. Should you have used anti-freeze drain it from the pump.
6. Remove any winterising pipe plugs if they were used.
7. Close all drain valves and replace the drain plug on the pump.
8. See priming for start-up method.

## SERVICING PUMP SEAL

Tools you will need. 4mm hex drive Allen key, flat head screwdriver, Molycote O-Ring grease.



- SHUT DOWN PUMP before working on the pump (UNPLUG IF POSSIBLE), power to the pump must be isolated.
- CLOSE ALL VALVES before working on the pump.
- RELEASE ALL PRESSURE before working on the pump.
- **DO NOT PROCEED UNTIL ALL THE ABOVE STEPS ARE FOLLOWED.**
- Remove the clear lid, remember to re-lubricate the O-Ring on this when servicing.
- Undo the unions and unbolt the pump from the floor, this will free the pump making it easier to work on.
- Remove all eight 4mm hex screws, this will release the wet end from the seal plate.
- Put the wet end to one side.
- Securing the drive shaft with a screwdriver, rotate the impeller anti-clockwise and it will unscrew from the motor shaft, on the back of the impeller you will locate the pump seal. The fan case can be removed to access end of the shaft.
- Be sure to replace the new one the correct way. Apply a small amount of 55 Molycote grease to the shaft of the impeller where the rubber part of the seal touches. Highlighted in **red** below.



- Should you need to access/change the slinger washer you will need to remove the seal plate to access to the other side.
- Remember it's always good to re lubricate O-Rings upon breakdown.
- When reassembling the pump, **the eight 4mm hex screws need to be tightened to 3 newton metres.** Tighten evenly ensuring an even seal, do not over tighten.

To see how to recycle packaging please visit:  
[http://www.sealedairprotects.com/eu/en/sustainability/recycle\\_instapak.aspx](http://www.sealedairprotects.com/eu/en/sustainability/recycle_instapak.aspx)

# AG Pump

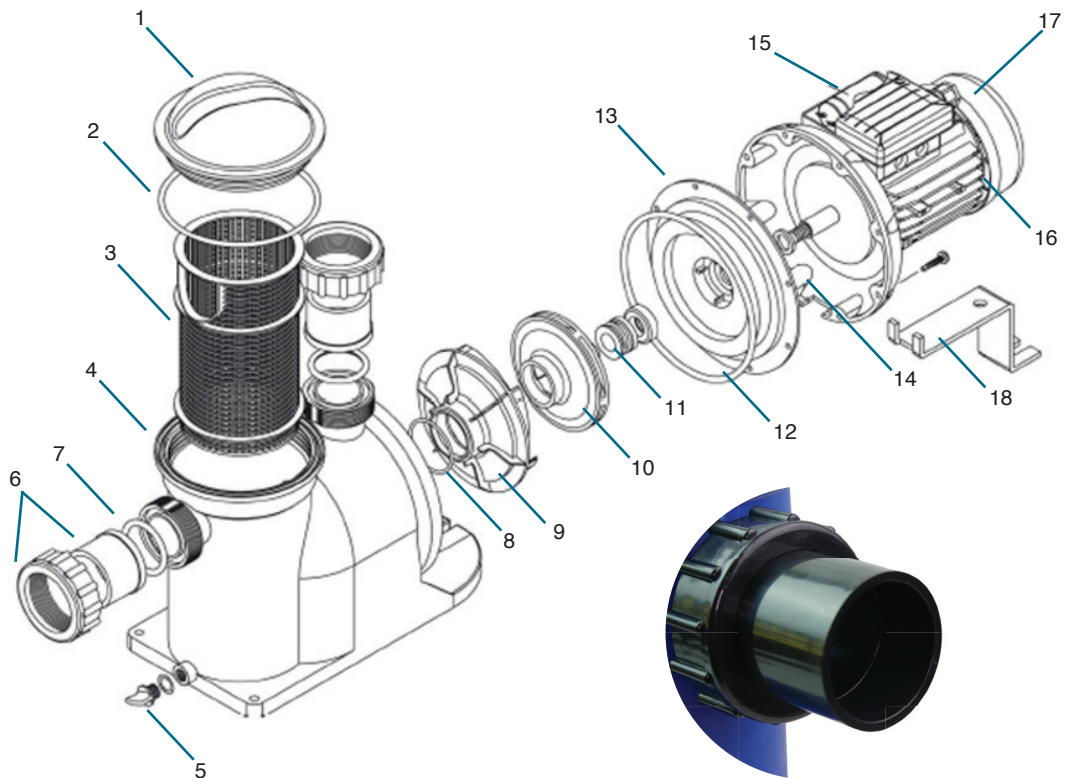

Item No.	Part Code	Part Description
1	UK01456	Clear Lid
2	UK00618	Lid O-Ring
3	UK01455	Strainer Basket
4	UK01454	Body
5	UK01566	Drain Plug incl. O-Ring 0.25" BSP
6	PPF5015AG	Union Nut & Sleeve 50mm/1.5" (Pk2)
7	UK00732	Port O-Ring
8	UK01458	Diffuser O-Ring
9	UK01453	Diffuser
10	UK01452	AG8 Impeller
10	UK01451	AG10 Impeller
10	UK01450	AG14 Impeller
10	UK01449	AG16 Impeller
11	81002490	Seal Assembly
12	UK01457	Seal Plate O-Ring
13	UK01448	Seal Plate
14	2848600	Slinger Washer
15	1090100000000	Capacitor 10uF AG8, AG10, AG14
15	1090120000000	Capacitor 12.5uF AG16
16	1350090000002	Fan
17	1125105000000	Fan Cover AG8, AG10, AG14, AG16
18	4300AG	Metal Foot Plate
-	UK01572	AG Lid Tool

## TROUBLESHOOTING GUIDE

SYMPTOMS	PROBABLE CAUSES	RECOMMENDED ACTION
1. Pump will not prime	1a. Suction air leak	<ul style="list-style-type: none"> <li>• Be sure water in pool is high enough to flow through skimmer.</li> <li>• Make sure strainer gasket is clean and properly positioned.</li> <li>• Hand tighten strainer cover down firmly.</li> <li>• Tighten all pipes and fittings on suction of pump.</li> <li>• Remove and replace pump seal.</li> </ul>
	1b. No water in pump	<ul style="list-style-type: none"> <li>• Make sure pump tank is full of water.</li> </ul>
	1c. Closed valves or blocked lines	<ul style="list-style-type: none"> <li>• Open all valves in system.</li> <li>• Clean skimmer and pump strainer.</li> <li>• Open pump and check for clogging.</li> </ul>
2. Motor does not turn	2a. No power to motor.	<ul style="list-style-type: none"> <li>• Check that all power switches are on.</li> <li>• Be sure fuse or circuit breaker is properly set.</li> <li>• Is timer properly set?</li> <li>• Check timer for proper operation.</li> <li>• Check motor wiring at terminals</li> </ul>
	2b. Pump jammed.	<ul style="list-style-type: none"> <li>• With power off turn shaft – it should spin freely. If not, electrician should disassemble and repair.</li> </ul>
3. Low flow	3a. Dirty filter	<ul style="list-style-type: none"> <li>• Back wash filter when filter pressure is 'high'.</li> </ul>
	3b. Dirty skimmer basket	<ul style="list-style-type: none"> <li>• Clean skimmer and pump strainer baskets.</li> </ul>
	3c. Suction air leak	<ul style="list-style-type: none"> <li>• (See problem 1)</li> </ul>
	3d. Closed valves or blocked lines	<ul style="list-style-type: none"> <li>• (See problem 1)</li> </ul>
4. Motor runs hot  These motors will run 'hot' to the touch. However, this is normal, they are designed that way. Thermal overload protector will function to turn them off if there is an overload of high temperature problem. Excessive heat can be caused by:	4a. Low or incorrect voltage	<ul style="list-style-type: none"> <li>• Wiring to be corrected by qualified electrician.</li> </ul>
	4b. Installed in direct sun	<ul style="list-style-type: none"> <li>• Shield motor from sun's rays.</li> </ul>
	4c. Poor ventilation	<ul style="list-style-type: none"> <li>• Do not cover or enclose motor</li> </ul>
5. Noisy operation of motor	5a. Worn bearings	<ul style="list-style-type: none"> <li>• Have an electrician replace bearings in motor.</li> </ul>



## TROUBLESHOOTING GUIDE

SYMPTOMS	PROBABLE CAUSES	RECOMMENDED ACTION
6. Noisy operation of pump	6a. Air leak in suction line. Bubbles in water returning to pool at inlet	<ul style="list-style-type: none"> <li>• Repair leak</li> <li>• Check suction pipe.</li> <li>• Is strainer cover in place?</li> <li>• Is cover gasket clean?</li> </ul>
	6b. Restricted suction line due to blockage or undersize pipe. Indicated by high vacuum reading at pump suction.	<ul style="list-style-type: none"> <li>• Have serviceman remove blockage or increase suction pip size.</li> <li>• Make sure strainer basket is clean.</li> <li>• Are all suction valves fully open?</li> </ul>
	6c. Foreign matter (gravel, metal etc.) in pump impeller	<ul style="list-style-type: none"> <li>• Have engineer disassemble pump and remove foreign matter from impeller.</li> </ul>
	6d. Cavitation	<ul style="list-style-type: none"> <li>• Improve suction conditions (reduce suction lift, reduce number of fittings, increase pipe size).</li> <li>• Increase discharge pressure and reduce flow by throttling discharge valve.</li> </ul>
7. Motor overload protection 'kicks out'	7a. Motor is improperly connected	<ul style="list-style-type: none"> <li>• Have electrician check wiring diagram on motor.</li> </ul>
	7b. Low voltage due to under sized wire or low incoming voltage.	<ul style="list-style-type: none"> <li>• Have electrician check with volt meter.</li> <li>• Increase size of supply wire.</li> <li>• Report low supply voltage to power company.</li> <li>• Voltage of motor must be</li> </ul>

**NOTE: ALL ELECTRICAL WORK MUST BE DONE BY A QUALIFIED ELECTRICIAN**

# NOTES

# NOTES



# Plastica

The UK's Leading Independent Swimming Pool Manufacturer and Distributor



[www.plasticapools.net](http://www.plasticapools.net)

Find us on



Address: Perimeter House, Napier Road, St Leonards on Sea, East Sussex, TN38 9NY  
Plastica Limited is registered in England and Wales with Company Number 1856576 and VAT Number: 100 1630 93